

Transport for NSW | Centre for Road Safety

Assessing the Safety Impact of Attachments on Motorcycle Helmets

Summary Report

July 2021

Contents

1	Key Findings	3
2	Background & Objectives	4
3	Measures and methods	5
	3.1. Initial testing	5
	3.2. Oblique impact testing	5
4	Results	8
	4.1 Adverse test results	9
5	Implications and Conclusion.....	11

1 Key Findings

- TfNSW commissioned research to assess the safety impacts of aftermarket camera and communication devices which are attached to motorcycle helmets.
- Conventional impact (drop) test methods contained in British Standard (BS) 6658:1985 '*Specification for protective helmets for vehicle users*' were not ideal to replicate the head and neck injury risk likely to occur in a real world motorcycle crash.
- An oblique impact test method, where test helmets hit a moving striker plate, were deemed to be a more biofidelic (human-like) test, and this method was used to conduct 220 impact tests with various helmets and attachments.
- The results revealed that attaching a camera or communication device to a motorcycle helmet does not, on average, increase the risk of head or neck injury to the person wearing the helmet, in a crash. Whilst some adverse results were found, there were no discernible patterns to these and the overall injury risk in these scenarios was marginal.
- The findings of the study informed changes to Transport for NSW policy, which now allow motorcycle riders to attach aftermarket camera and communication devices, provided they do so properly and following manufacturers' instructions.

2 Background & Objectives

Over the last decade many wearable, light weight, small camera and communication systems have been developed. These devices are sold with mounts to facilitate attaching them to a motorcycle helmet. Without evidence to the contrary, it has generally been assumed that mounting a device to a motorcycle helmet reduces its safety performance, as the helmet was not designed and tested with the attachment.

Until recently, devices and external protrusions on motorcycle helmets were assessed in Australia using impact (drop) test methods specified under British Standard (BS) 6658:1985 '*Specification for protective helmets for vehicle users*'. These test methods were mandated in Australian Standard AS/NZS 1698-2006 '*Protective Helmets for Vehicle Users*' as well as UNECE 22.05 '*Uniform Provisions Concerning the Approval of Protective Helmets and of Their Visors for Drivers and Passengers of Motor Cycles and Mopeds*', and applied to the evaluation of device attachments.

TfNSW commissioned McIntosh Consultancy and Research (MCR), to conduct a series of impact tests, with different helmets and attachments, to determine:

- Whether the BS 6658:1985 impact test methods were suitable for the purposes of measuring the potential risks to riders of attaching devices (such as cameras and Bluetooth communication units) to motorcycle helmets;
- Whether an alternate, oblique impact test method was a more appropriate method for measuring the potential risks to riders of attaching devices to motorcycle helmets;
- Whether there were changes in risk of head and neck injury resulting from attaching devices to motorcycle helmets.

3 Measures and methods

The study was conducted in two testing phases - an initial set of testing using the impact (drop) test method, and the oblique impact testing. Both test phases were conducted at TfNSW's Crashlab facility in Huntingwood, NSW.

3.1. Initial testing

Laboratory tests were undertaken using the BS 6658:1985 section 6.4 linear impact (drop) test method, which is referenced in AS/NZS 1698-2006 for the evaluation of non-rigid external projections of a height greater than 5mm, and in UNECE 22.05 as a test for projections. Initial tests with the unmodified BS 6658:1985 section 6.4 test method identified a number of 'failures' against the BS 6658:1985 performance criteria. With reference to the BS 6658:1985 requirements, a number of combinations of mount, attachment and/or camera provisionally failed.

However, on further evaluation of this test method, it became clear that the BS 6658:1985 section 6.4 test method was not specific to the presence of a motorcycle helmet attachment. When the tests were video recorded and an instrumented headform used, there was no observable deviation of the movement of the helmet during the interaction between the attachment with the anvil and no observable rotation of the helmet. It was concluded that the British Standards method, BS 6558:1985 section 6.4, was not a biofidelic (human-like) test. As a result, all further testing was conducted using the oblique impact test rig.

3.2. Oblique impact testing

The oblique impact test rig was developed in the late 2000s by Dr Andrew McIntosh and colleagues at UNSW. The research was funded by an ARC Linkage Grant in partnership with the then NSW Roads and Traffic Authority (RTA). A schematic of the test rig is shown as Figure 1.

To conduct an oblique impact simulation using this rig, a helmet is placed on an instrumented Hybrid III crash test dummy head and neck assembly, which is then dropped onto a moving anvil (or striker plate as depicted in Figure 1) so that it contacts the anvil at a pre-determined impact location. The rig was designed to better simulate the impact that might be experienced by a rider, who has come off their motorcycle following a crash. The height of the drop assembly and speed of the moving anvil can be varied, as can the anvil surface type and head and neck orientations.

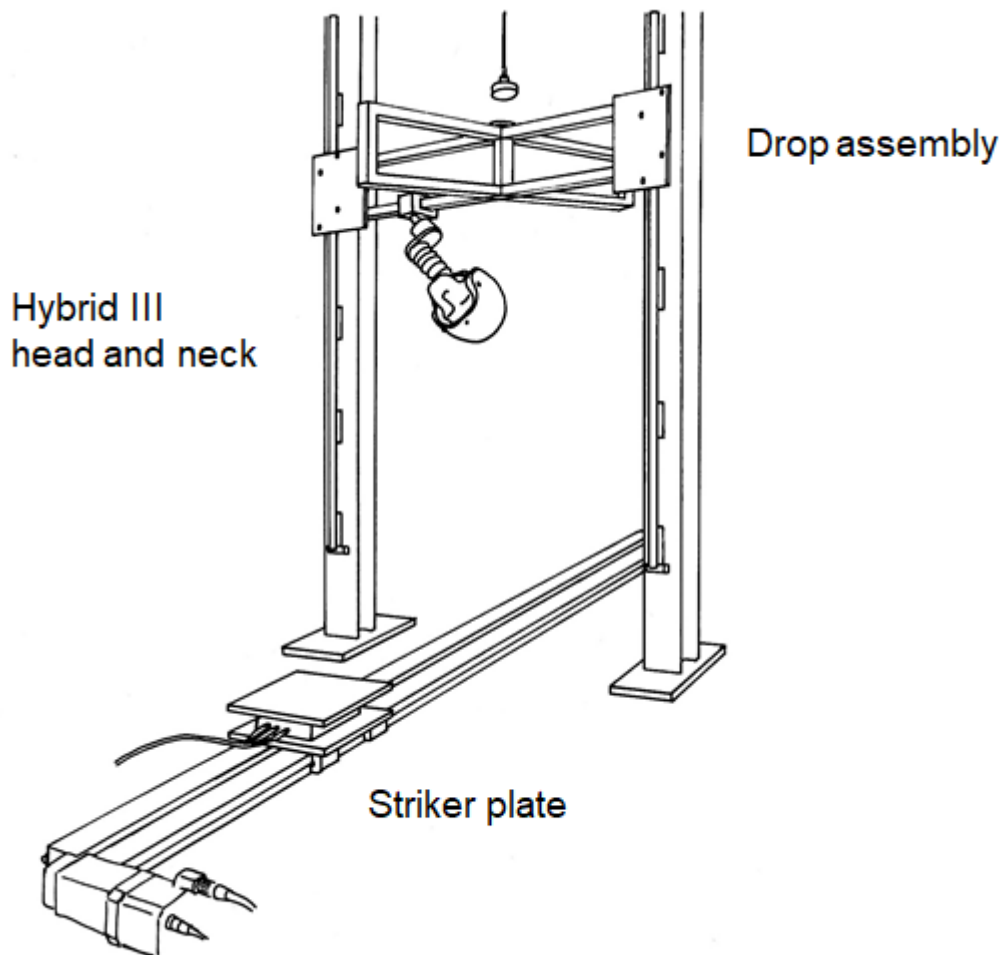

Figure 1: Schematic of oblique impact test rig

The risk of head and neck injury was assessed using biomechanical head and neck loads measured on a crash test dummy head and neck (Hybrid III) attached to the drop assembly. These measures include peak headform linear acceleration, peak headform angular velocity and peak headform angular acceleration.

Initially, 40 oblique impact tests were conducted as a pilot study, on multiple helmets, with attachment tests, as well as no attachment reference tests. After completing and analysing the pilot data, the program of research was subjected to an external, international peer review. The reviewers endorsed the new test method and recommended additional testing to include a broader range of impact scenarios and more severe impacts.

Following this pilot study, the main study was conducted where head injury risks were assessed based on impact tests on a variety of helmets with attachments (n=154) and paired no attachment reference tests (n=66). New attachments were also assessed in the main study, for example NuViz (a head up display device), and attachments mounted on the lower edge of the helmet, such as communication units.

In total, 220 impact tests were conducted utilising:

- four impact sites
 - Site A – Front lateral
 - Site B – Helmet rim lateral
 - Site C – Rear lateral
 - Site D – Crown
- six helmet models
 - Airoh Storm
 - RJays Apex
 - Roof Cooper
 - Scorpion Boulevard
 - Scorpion Vintage
 - Shark Ridill
- three impact surfaces
 - flat surface with abrasive surface (with P80 waterproof T423 sanding sheet interface)
 - flat surface with polyurethane foam surface interface
 - bar anvil surface
- five attachments (devices and corresponding mounts)
 - Drift Ghost 4K
 - Go-Pro camera
 - NuViz head up display unit (mounted on chin bar)
 - Scala communication unit
 - Sena Bluetooth communication unit
- three drop heights, representing increasing impact severity
 - 1200mm
 - 1600mm
 - 1800mm
- three attachment fixation methods
 - an adhesive tape (3M™ VHB™ tape). Some of the mounts were supplied with equivalent tape already attached
 - a dual-lock re-attachable tape (3M™ 250/250 Dual Lock™). Dual Lock™ is a hook and loop re-closable fastener.
 - a clamping system around the lower edge of the helmet shell, as supplied by the device manufacturer.

4 Results

The research undertaken found that attaching a camera or communication device to a motorcycle helmet does not, on average, increase the risk of head or neck injury to the person wearing the helmet in a crash. In fact, in the majority of cases, the results revealed that the attachment reduced the risk of head and neck injury as assessed in laboratory tests. This was considered to be a result of the energy absorbed when the device separated from the helmet upon impact.

Four biomechanical measurements of head impact responses showed, on average, a reduction in magnitude in helmet attachment tests, compared with the helmet only reference tests:

1. Head Injury Criterion (HIC) = 42% average reduction (SD = 28%)
2. Highest linear acceleration experienced by head = 23% average reduction (SD = 19%)
3. Peak angular head velocity = 10% average reduction (SD = 19%)
4. Highest angular acceleration experienced by head = 22% average reduction (SD = 30%)

When the predicted likelihood of head injury from helmet attachment tests were compared with matched helmet only reference tests, on average, there was a 5 percentage point reduction (SD = 5%) in the likelihood of serious head injury with an attachment, based on linear head acceleration.

Further, there was a 21 percentage point reduction (SD = 29%) in moderate to critical head injury with an attachment based on angular head acceleration, compared with matched helmet only reference tests.

For neck loads, the following criteria were used as markers for the onset of neck injury:

- $|F_x|$ and $|F_y| > 3100$ N (shear forces)
- F_z (tension) > 3300 N
- F_z (compression) < -4000 N
- $|M_x| > 75$ Nm
- M_y (flexion) > 190 Nm
- M_y (extension) < -57 Nm.

1. The magnitudes of the upper neck shear force components, F_x and F_y , were less than the 3100 N limit, in all 188 tests in which neck loads were measured.
2. The magnitudes of the upper neck F_z exceeded the tensile and compressive limits, of +3300 N and -4000 N, respectively, in 90 (48%) attachment and reference tests.
 - a. There were 35 tests in which the F_z exceeded 3300 N in tension; 22 helmet attachment tests and 13 helmet only reference tests. There was no pattern, except that these were typically Site B (Helmet rim lateral) tests. The highest tensile load was in the Roof Cooper with Sena Bluetooth mount test. There were six tests in which the F_z exceeded 4000 N in tension; four of these were helmet only reference tests (range +4060 to +4760 N).
 - b. There were 55 tests in which the F_z (compression) exceeded -4000 N; 27 helmet attachment tests and 28 helmet only reference tests. The greatest compressive neck

force was measured in the five Site A, bar anvil surface, RJays Apex helmet only reference tests (range -5710 N to -6190 N).

3. During the contact phase with the striker plate, M_x was less than the 75 Nm criterion in the majority of tests. M_x exceeded this criterion, post separation, in approximately 36% of tests, which may reflect specific aspects of the Hybrid III neck and test rig configuration.
4. The magnitudes of the upper neck flexion bending moment, M_y (flexion), did not exceed the 190 Nm limit, in any test.
5. The magnitudes of the upper neck extension bending moment, M_y (extension), exceeded the -57 Nm limit during the contact phase of the helmet on the striker plate, in eight cases - three bar anvil tests with mount only, two Site C flat anvil with mount only and three site C helmet only reference tests. In these cases, -57 Nm was exceeded by a small margin, e.g. approximately -1 to -13 Nm.

Neck injury risks were assessed in a subset of the tests. Impact tests on helmets with attachments ($n=128$) were compared with paired helmet only reference tests ($n=60$). The tests included three impact sites (sites A, B & C), six helmet models, three impact surfaces and five attachments (including mount only tests), and fixations as per supplier instructions (adhesive tape, or in one case, a clamping system around the lower edge of the helmet shell). Greatest neck forces and moments in helmet attachment tests showed, on average, no change or a reduction in magnitude, compared with the helmet only reference tests:

1. Greatest force applied to the neck = 16% average reduction (SD = 21%)
2. Greatest moment applied to the neck = 0% average reduction (SD = 17%)

4.1 Adverse test results

There was a small number of adverse findings for specific helmet, attachment and impact configurations. There was no discernible pattern to these adverse findings and the overall injury risk in these scenarios was marginal, compared with the helmet only reference tests. Some examples are summarised below:

1. Scorpion Vintage helmet with a GoPro mount only (no device). In the Site A severe (1800 mm drop) test, PRA (Peak rotational [angular] acceleration resultant) was 28,557 rad/s^2 , compared with 18,461 rad/s^2 in the reference test. These are high magnitude angular head accelerations and associated with a very high likelihood of AIS severity 2 to 5 brain injury. However, PRA_{xy} (Peak rotational acceleration resultant x and y) was 11,630 rad/s^2 with attachment, compared with 14,773 rad/s^2 in the reference test. It was observed that the helmet model shell often fractured and there was paint delamination with the mount and in reference tests.
2. Scorpion Boulevard helmet with a Drift mount only (no device). In the Site A severe (1800 mm drop) test, PRA was 15,814 rad/s^2 compared with 15,772 rad/s^2 in the reference test. PRA_{xy} was 10,215 rad/s^2 with attachment, compared with 15,765 rad/s^2 in the reference test. Neck loads, striker table force and PLA (Peak linear acceleration resultant) were either similar or less in the Drift attachment test, compared with the reference test. Delamination and shell fracture did not occur, and the mount did not detach from the helmet.

3. Apex helmet with GoPro mount only (no device) into polyurethane foam anvil. Three tests were conducted with the configuration of Site C 1500 mm drop test with GoPro mount into the foam anvil. In general, head and neck loads in the Site C GoPro mount only tests were comparable to or less than the reference tests, except for PRA and PRA_{xy}. In this test, PRA was 10,356 rad/s² with GoPro mount, compared with an average PRA from five reference tests of 7,543 rad/s². In this test, PRA_{xy} was 9,137 rad/s² with GoPro mount, compared with an average PRA_{xy} from five reference tests of 6,777 rad/s². The y-component angular velocity and acceleration are the main contributors to the resultants.
4. Roof Cooper helmet with Sena Bluetooth Unit. Striker force with Sena attachment was 8,323 N, compared with 6,883 N in the reference test. PLA with Sena attachment was 118 g, compared with 63 g in the reference test. PRV (Peak rotational [angular] velocity) was 58 rad/s with Sena attachment, compared with 54 rad/s in the reference test. PRA was 10,124 rad/s² with Sena attachment, compared with 8,873 rad/s² in the reference test. Resultant neck moment was 87.7 Nm with Sena attachment, compared with 72.4 Nm in the reference test. Resultant neck force was 5.7 kN with Sena attachment, compared with 2.7 kN in the reference test.

5 Implications and Conclusion

The results of the study suggest that, when attached appropriately, motorcycle helmet attachments are not a significant hazard to riders, based on the main biomechanical variables measured in the study. Further, these results were largely consistent across any attachment, any impact orientation, severity or any impact surface, compared with no attachment, helmet only reference tests.

However, when specific combinations of test sites, helmet models and attachments are considered, specific biomechanical outputs for some helmet plus attachment tests were found to exceed the safety criterion, in magnitude (i.e. increased head and/or neck injury risk), compared with the reference helmet test outputs. This varies on a case-by-case basis. In many cases, but not all, these differences are small. No obvious pattern emerged from the analysis regarding the most hazardous attachments.

The study had a number of key strengths and limitations. Some of the key strengths of the tests were:

- A large range of motorcycle helmet models (n=6) were included. Helmets were selected based on their external characteristics (surface finish and profile), type (open face and full face) and assessed safety performance (star rating in CRASH).
- A large range of motorcycle helmet attachments were assessed, including five camera systems and four communication systems, and the NuViz head-up display unit.
- A replicable and biofidelic test method was applied.
- Three attachment fixation methods were assessed.
- Assessment of reference helmet with no attachment, helmet with mount only, helmet with attachment.
- Four impact orientations/test sites were tested.
- Three impact anvil surfaces were tested.

However, some of the key limitations of the tests were:

- Fixation methods judged more likely to compromise the performance of the helmet, e.g. bolting or riveting or strong adhesive, were not assessed.
- There are limitations to the human-like performance of the Hybrid III head and neck. For example, in crown impacts (Site D), the Hybrid III neck behaved like a spring. However, through selection of tests that did not overload the Hybrid III head and neck, and comparisons of the helmet with attachment to helmet only configurations, the relative effect of the attachment was measured.
- The study was performed in the laboratory only, and as such, the safety performance of helmets with attachments should be explored in real world settings, to validate these results.

Based on the findings, that devices appropriately attached to helmets do not significantly increase the risk of head or neck injury, Transport for NSW instituted a policy change that allows for devices to be attached to helmets, so long as the attachments do not compromise the structure and integrity of the helmet.

Transport for NSW, Centre for Road Safety

Website roadsafety.transport.nsw.gov.au

Contact roadsafety.transport.nsw.gov.au/contactus

July 2021

© Transport for NSW